

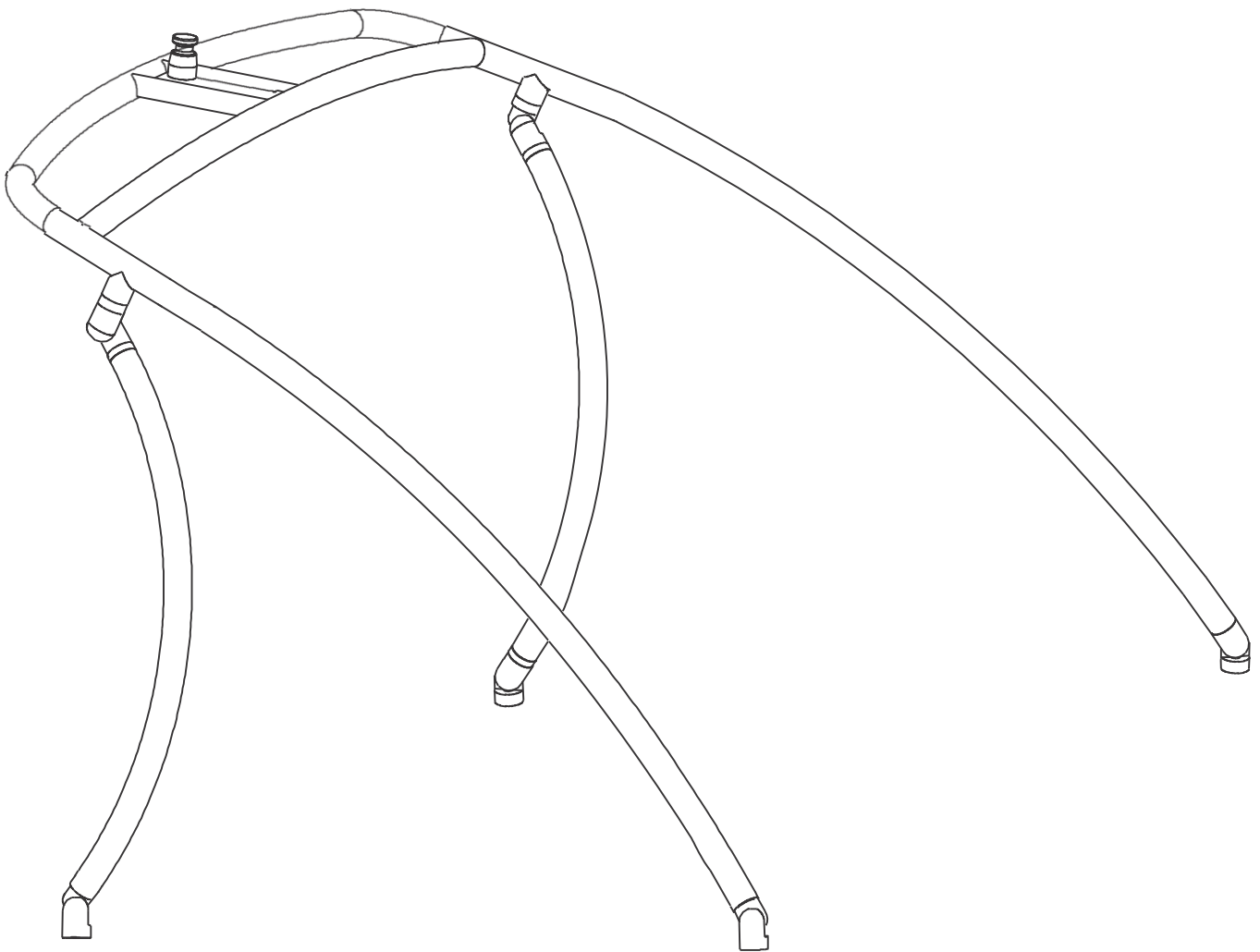

INDY PRO WAKEBOARD TOWER



INSTALLATION GUIDE

EXPLODED VIEW

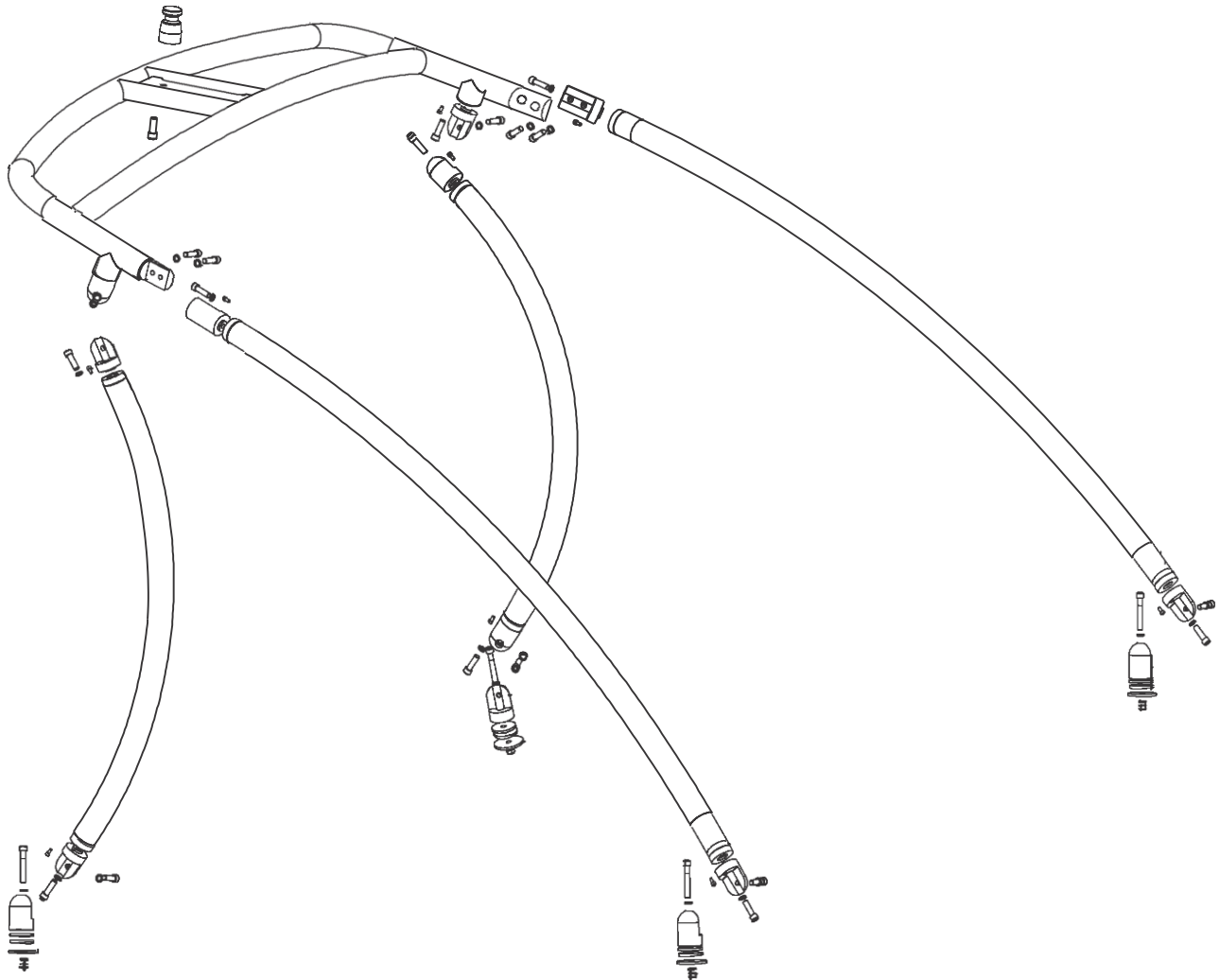

STEP 1: REMOVE TRANSPORT RUBBER CAPS FROM LEG ENDS!

Unpack and check and compare the contents of the box to parts list (next page) It is recommended to have the tower professionally installed for peace of mind

Read the complete installation guide prior to installation

If you are NOT sure of any part of the guide or you have question contact the Indy Wakeboard Towers direct.

PARTS LIST

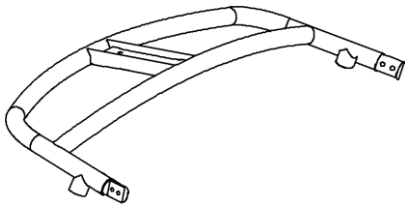

1 x Top Section



2 x Short Curved Rear Legs

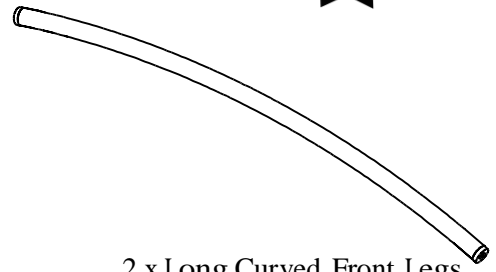

2 x Long Curved Front Legs



10 x M6 short Bolts
(already installed in fittings)

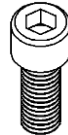

20 x M12 Short Bolts



4 x M12 Long Bolts



24 x Split Washers



4 x small Nylon washer



4 x Locking Nut

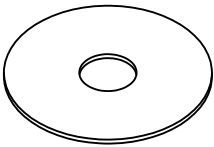

4 x Large Nylon Plates

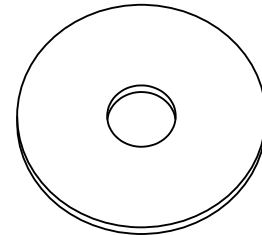

4 x Large 70mm Alloy plates

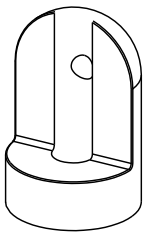

4 x Flat Base Deck Mounts

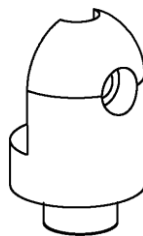

6 x Open Hole leg fittings



2 x Threaded hole fittings

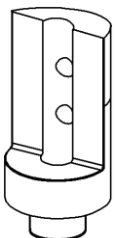

2 x Square front Leg fittings

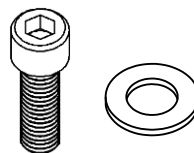

1 x Tow Point Bolt and Washer



1 x Tow Point

Step 2: Attach end fittings to long curved Front Legs



The front legs use two types of fittings.

A Square shape which is used to attach to the top section

A rounded end shape with an open hole to attach to the deck mounts

First we will attach the Square fitting to one end of the leg only

Note the square shape fitting has two threaded holes to attach to top section

Note the base of has a raised circle area.

Note the end of the tower leg has a counter sunk circle with internal thread

Insert the raised circle base of the fitting into the counter sunk area of the leg end

Use the M12 bolt and split washer inserted through the center and tighten

Note you can rotate the fitting to the angle required. Tighten when correct position.

Tighten the small M6 bolt in the small threaded hole last to lock the fitting.

NOTE: For now allow the fitting to rotate slightly for adjustment.

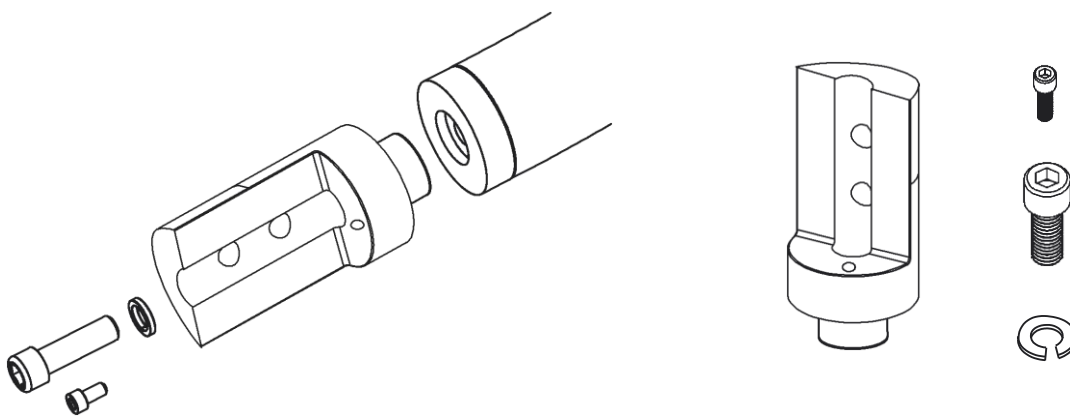

Next we will attach the curved Leg End fitting to the opposite end of the front leg. This end fitting will attach to the threaded deck mount on the boat.

Note the curve shape fitting has an open hole through the side to attach to the threaded deck mount

Note the base of has a raised circle area

Note the end of the tower leg has a counter sunk circle with internal thread

Insert the raised circle base of the fitting into the counter sunk area of the leg end

Use the M12 bolt and split washer inserted through the center and tighten

Note you can rotate the fitting

Use the small M6 bolt in the small threaded hole to lock the fitting from rotating

For now allow the fitting to rotate slightly for adjustment.

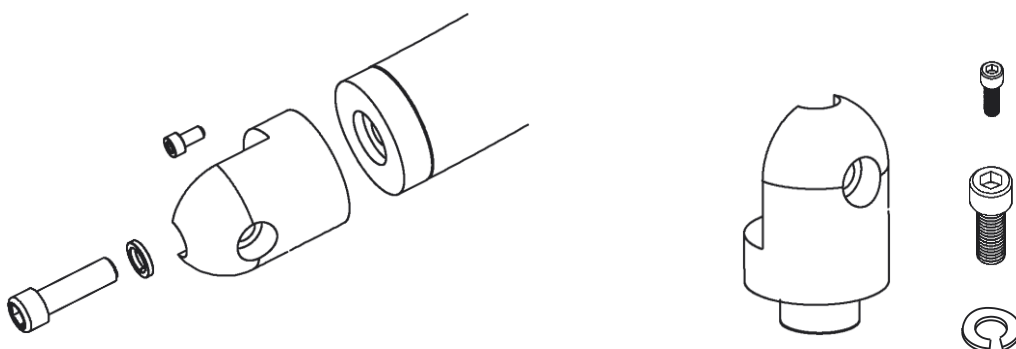

Step 3: Attaching end fittings to short curved Rear Legs



Rounded end fitting with an open hole are attached to both ends of the rear legs

Note the curved shape fitting has an open hole for attaching to threaded deck mounts and top

Note the base of has a raised circle area

Note the end of the tower legs has a counter sunk circle with internal thread

Insert the raised circle base of the fitting into the counter sunk area of the leg end

Use the M12 bolt and split washer inserted through the center and tighten

Note you can rotate the fitting

Use the small M6 bolt in the small threaded hole to lock the fitting from rotating

For now allow the fitting to rotate slightly for adjustment.

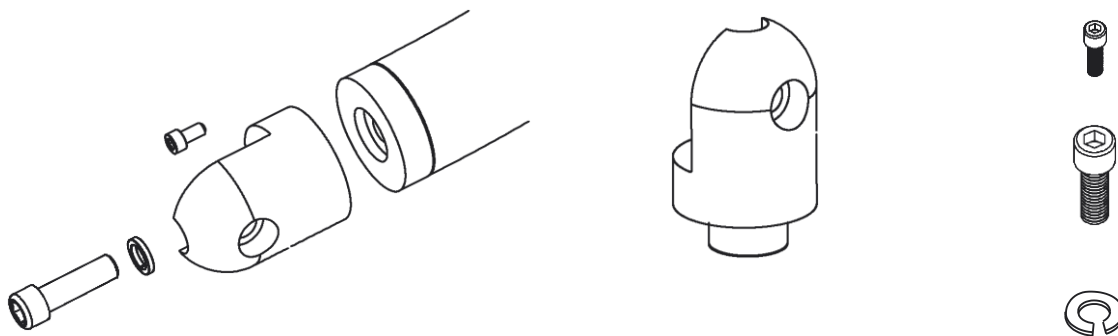

Step 3: Attaching fittings to top section

Rounded end fitting with a threaded hole

Note the curved shape fitting has an threaded hole for attaching to the open hole end fittings on rear leg

Note the base of has a raised circle area

Note the tower top section has a short welded fitting with a counter sunk circle area with a thread

Insert the raised circle base of the fitting into the counter sunk area of the top section

Use the M12 bolt and split washer inserted through the center and tighten

Note you can rotate the fitting

Rotate the fitting so the area with the threaded hole faces inwards

Use the small M6 bolt to lock the fitting after in correct position and center tight.

For now allow the fitting to rotate slightly for adjustment.

Align the fitting to to run parallel to the top section tube

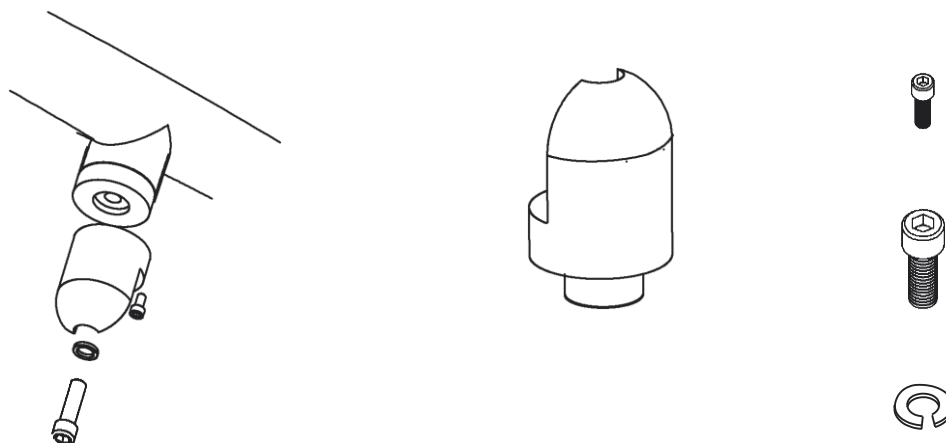

Step 4: Attaching Tow point to top section

Round contoured and shape fitting with flat base and threaded hole

Note the nice curves to take you wakeboard rope.

Note the flat base

Note the threaded hole in the base

Note the Flat welded plate on the top section between the two bars with a pre drilled hole

Note the Indy badge on the tower top section

Place the tow point on the top of the "at plate of the top section

Insert bolt with large washer underneath the "at alloy plate and tighten into the Tow point.

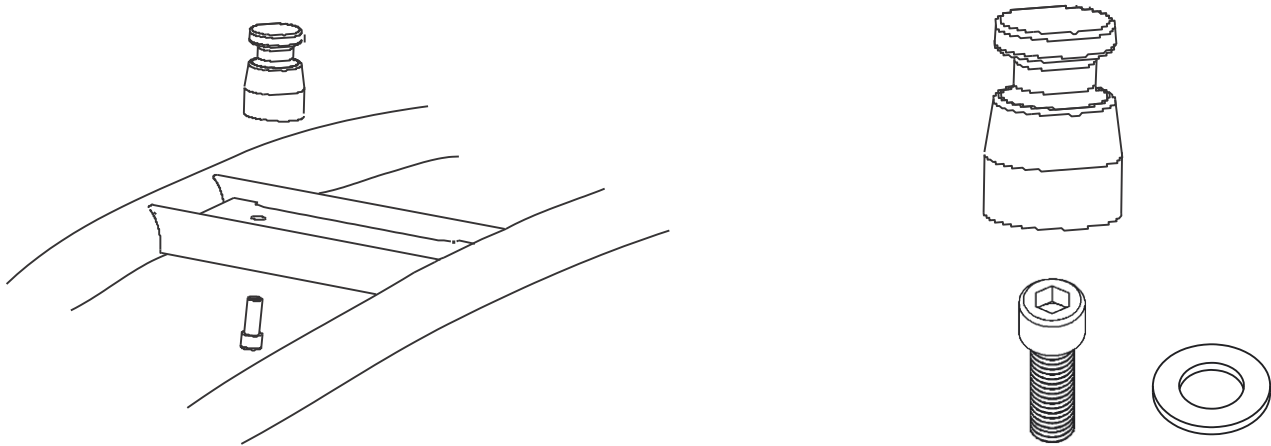

Step 6: Attach the long curved Front legs to the top section.

Place the top section on the floor so you can read the logo.

Attach the long curved front legs to the top section note the square end fittings with two holes

Attach the Square end fitting on the legs to the top section.

Note the front legs should be creating an arc to the floor.

Note you should be able to rotate the legs slightly which will move the front mounting points wider and narrower.

NOTE

You can now measure where the mount will be on the front deck and adjust to see what the tower will look like front on before drilling any holes.

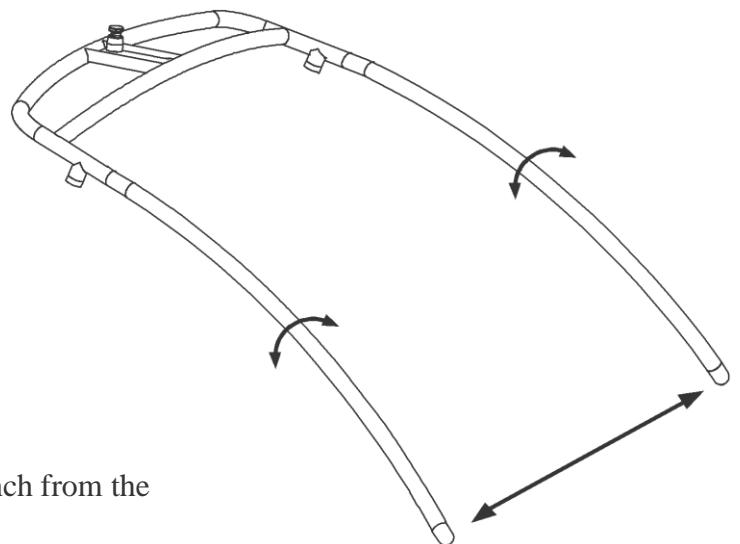

NOTE

You can also attach the rear legs and position 75inch from the front and adjust to see how the tower looks.

Step 5: Assembly of Deck Mounts



Note the Flat base of Deck Mounts

Note the M12 hole through the center

Note the threaded hole in the Fitting

DECK MOUNTS TO BE PLACE ON FLAT SURFACE....

Flat deck assembly

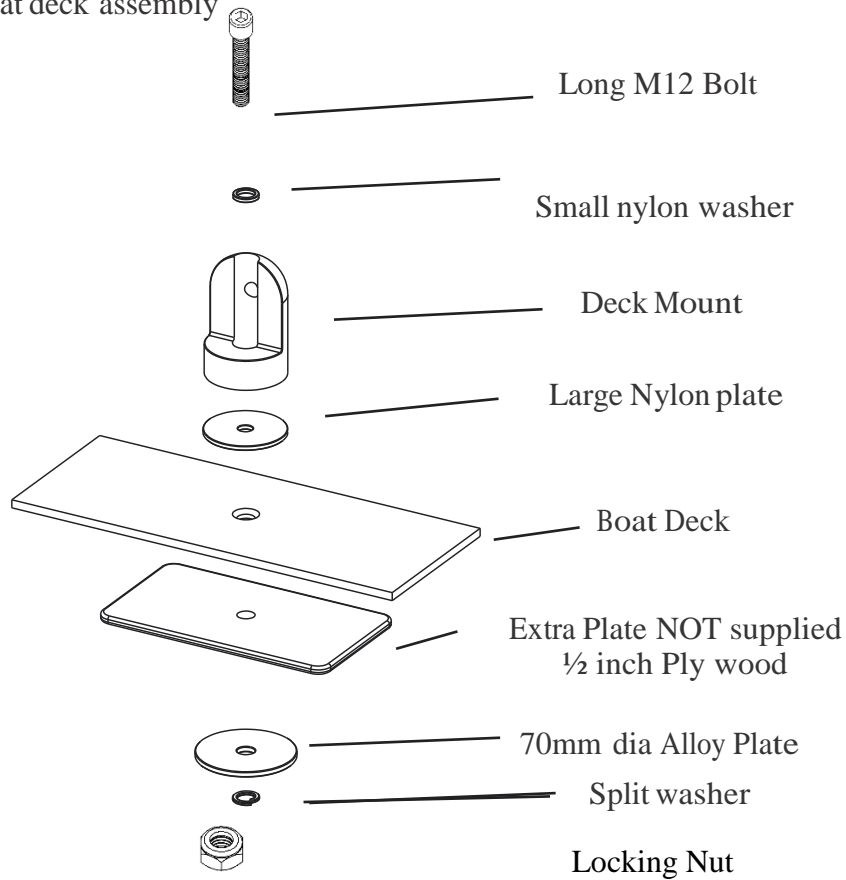

Step 7: Installation of Front Deck Mounts onto Boat.

DO NOT USE RUBBER PADS – HARD NYLON DIRECT ONTO FLAT SURFACE!

Distance between Front Mounts - 70inch - 102inches.

Recommended to be placed on the flat deck in front of Windscreen (Out wide)

Use extra plate of (ply or Alloy) underneath the deck between the our alloy plate and the deck of the boat (see picture above)

WARNING – BEFORE DRILLING!

CHECK! That you have clear access. Check for objects, wires or other hazards.

Do not measure from windscreen, cleats, vents or use as a reference point.

These objects are not always square and the same as the opposite side.

It is best to use the front of the boat as the reference point and also the top edge of the deck mould or similar if possible. Always triple measure and check before drilling

Tighten the deck mounts firm, if the will not rotate under pressure or leverage from attaching leg check the assembly is correct. (note they will be very hard to rotate by hand)



Distance between rear mounts (side to side) 75inch to 102inch Wide

Distance from front to rear mounts 75inch.

DO NOT USE RUBBER PADS ! Rubber will cause movement.

DO NOT PUT ON CURVED SURFACE ! this will cause movement.

Rear deck mounts are to be on the side of the boat (flat surface on angle sides)

Place the deck mounts up as high as possible on the side, near the side window

Top edge/corner of the fibreglass. Or on sides near top edge/corner on angle is Ok.

As long as surface is flat.This area is the thickness near the corners.

If curved surface this will cause movement – Best to shape Nylon disc to suit curve.

Measure back from front deck mounts 75inches from the FRONT.

Mark out the position of rear deck mount using the mount, in position up high described above. Repeat on other side.

Triple measure, check under deck before drilling and install deck mounts.

Step 8: Attaching Tower to deck mounts.

Measure the distance between the FRONT deck mounts, you have installed.

Adjust the front legs on the assembled tower on the Floor.

If 2 people adjust the front legs to measurement of mounts.

Lift only the front legs and top section and attach.

Check lifting and laying down works correct. Lay down on windscreen.

Attach rear legs to the deck mounts. Lift the tower up and attach rear legs to the top section.

(Leave the legs slightly loose and also the fitting to the top so you can adjust to suit)

If by yourself, you can attach 1 x front leg at a time to the top section, leave leg resting on Windscreen, put towels down. Attach rear legs to the deck mounts.

Lift the tower up and attach rear legs to the top section.

(Leave the legs slightly loose and also the fitting to the top so you can adjust to suit)

Step 9: Check tower position – Loctite/ Tighten

Check that the tower is inline and square, Look from the front and rear.

Checking the top section is level and tow point centered.

NOTE: By rotating the front legs you can adjust the alignment of the top section.

You can also adjust the rear leg shapes to adjust the alignment.

You can rotate the fitting going into the top section + the rear legs to adjust the rear leg.

Once you have the tower square and in position mark across every joint as a reference.

REMOVE one fitting at a time whilst tower is attached to the boat (mark across joint for alignment)

Place loctite on the surface of fitting and end of tubes where they meet.

Place lock tight on the M12 and M6 bolt.

Line up the reference mark you made and lock the center M12 bolt first, then the small M6 set bolt.

REPEAT the process on all fittings on the tower.

FOR LOWERING & RAISING watch video at www.indywakeboardtowers.com



CARE AND MAINTENANCE

Be sure to check and tighten all bolts and connections prior to every use.

Be cautious when towing or driving under obstacles, low hanging structures or trees

Leave tower in the erect position when towing behind a vehicle

Use soap and water to clean your tower. Avoid abrasive material that might scratch or damage the tower protective finish.

Always rinse and wipe down tower after contact with salt (brackish) water.

WARRANTY

Indy warrants the product (not including other 3rd party accessories) against manufactures defects to the original purchaser only.

To claim you must contact Indy or its Distributor. The product/part is to be sent to the Distributor for inspection where it will either be repaired or replaced. (unless otherwise agreed in writing) The customer is liable for costs associated in shipping the product/part to Indy.

Indy is not responsible for personal injury or damage to the boat caused by the use of the tower or any transport charges or cost of installation or removal of the tower. Indy is not liability for direct or indirect or consequential damages resulting from delay or improper installation.

Warranty does not cover Anodised, polished and powder coated surfaces as well as any hardware corrosion they are specifically excluded as their care and use can not be controlled by Indy.

Warranty does not cover the spider coat gel cracking or damage from the installation or use of the tower on your boat. No dealer, retailer or manufacturer is the agent of James G Pty Ltd and may not assume any liability in connection with this warranty. This warranty is in lieu of all.

WARNING

The construction of your boat, design of the deck, thickness of deck and walls and overall design may cause movement at the mounting points. Towers will move and vibrate. A tower will only move when the base is unstable from the boats fibreglass flexing, this can not be controlled.

If the construction of your boat causes movement at the mounting points or incorrect mounting location creates added pressure on joints increasing movement of the tower it voids warranty.

If in doubt do not install the tower.

Check all bolts and parts prior to use, especially after towing behind a vehicle, lowering and raising after storage. At the beginning of season check the internal bolts, and also after any extended long driving trips.

WARNING

Do not stand, climb or jump on tower, do not tow a boat behind a vehicle with the tower lowered. Do Not Ski, tow tubes, boats or other watercraft from the tower. Watch out whilst moving under objects, such as bridges, low building and trees.

www.indywakeboardtowers.com